

ENGLISH

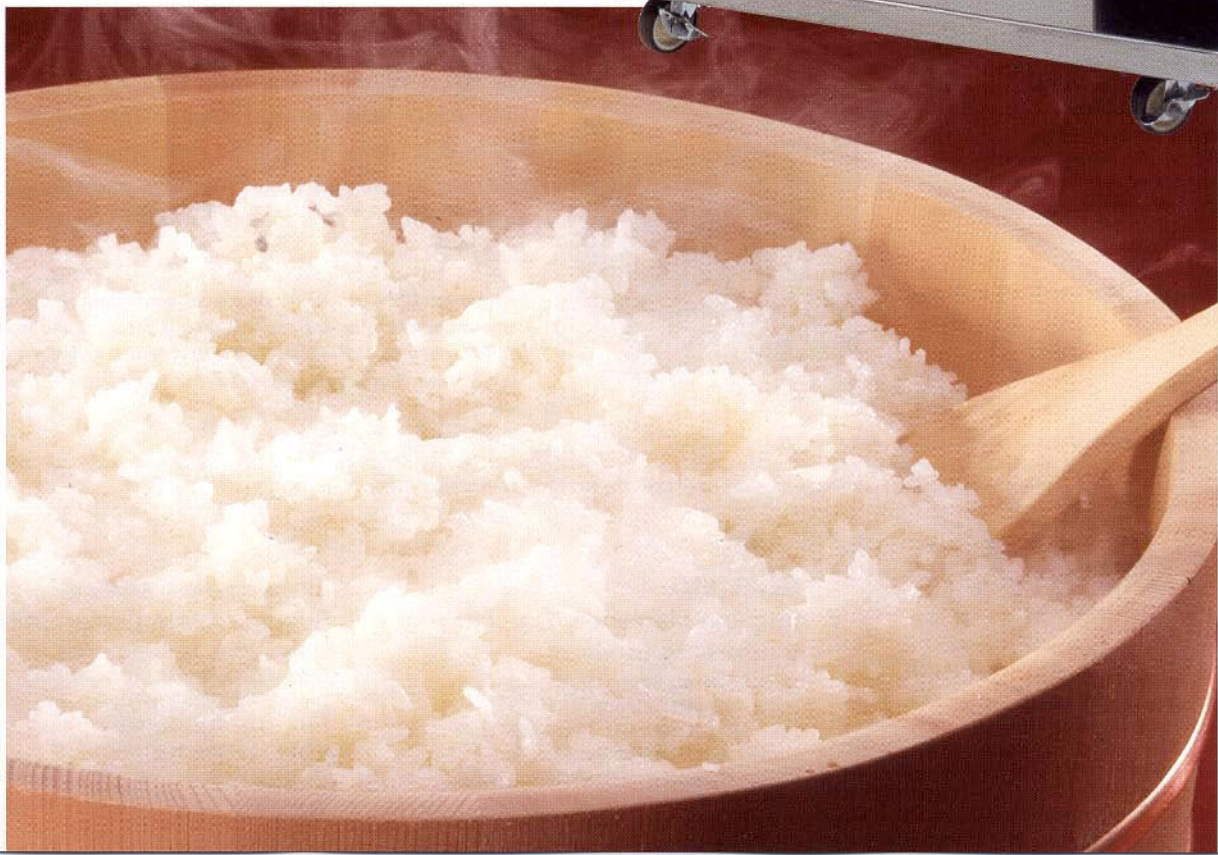

Cooked-Rice Mixer  
**"SHARIKKA"**  
**MCR-UNC**

Turn the most delicate aspect of sushi preparation, the blending of rice and vinegar, into an automatic process that yields perfect results.

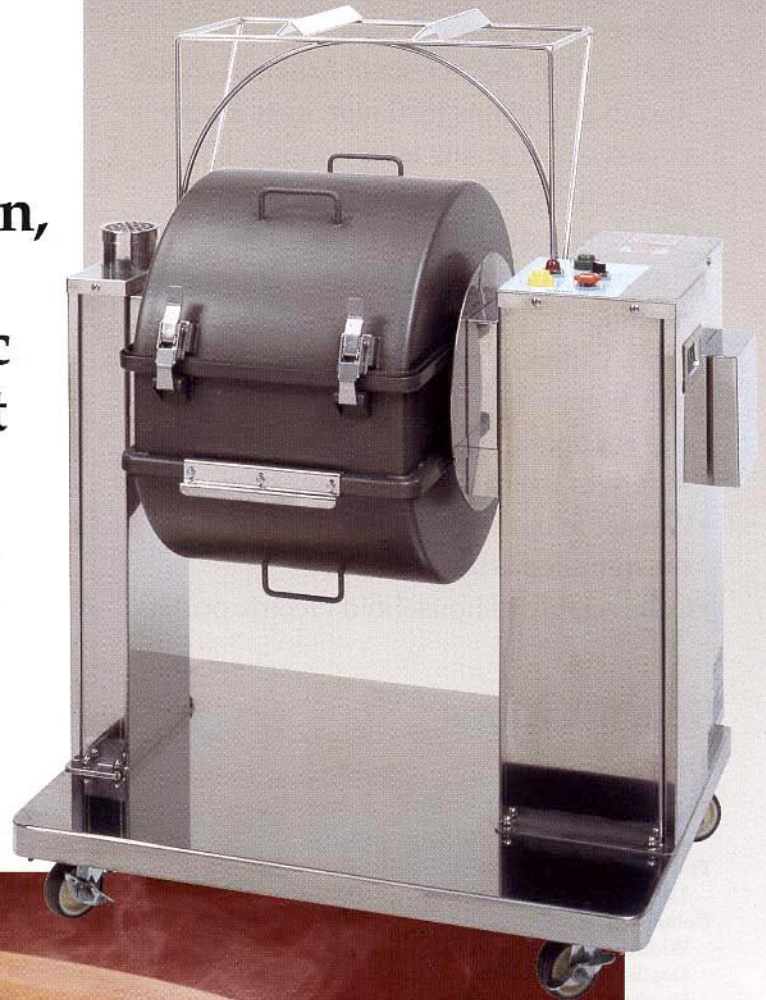

## Features

- Particularly through the use of Suzumo's high-grade Colonnade® sushi vinegar, the *Sharikka* MCR automatically produces perfect sushi rice each time through a mixing process, which covers each grain of rice with a layer of colloid. This assures that the rice stays firm and moist, and that it retains its flavor, over longer periods even at low temperature of between 5°C~15°C.
- The *shari* is discharged from the *Sharikka* drum through a simple button-operated method.
- Three different mixing settings are available, depending on the type of rice used. Pre-set operating programs determine the length of the different mixing processes.
- Washable parts can be dismantled and reassembled without tools.
- Connectable to household electric outlets.

## Specifications

### Type

*Sharikka* MCR-UNC

### Power

AC100V-240V, 50-60 Hz Single phase

### Power consumption

130W

### Robot dimensions (in mm)

Width 810 mm (32 in)  
Depth 645 mm (26 in)  
Height 1,120 mm (44 in)

\* The dimensions do not contain bumps and bosses.

### Rice Amount Capacity

Maximum 15kg (33 lb) of cooked rice

### Mechanism

Fully automatic  
(Placing the rice into the drum is done manually.)

## Dimensions

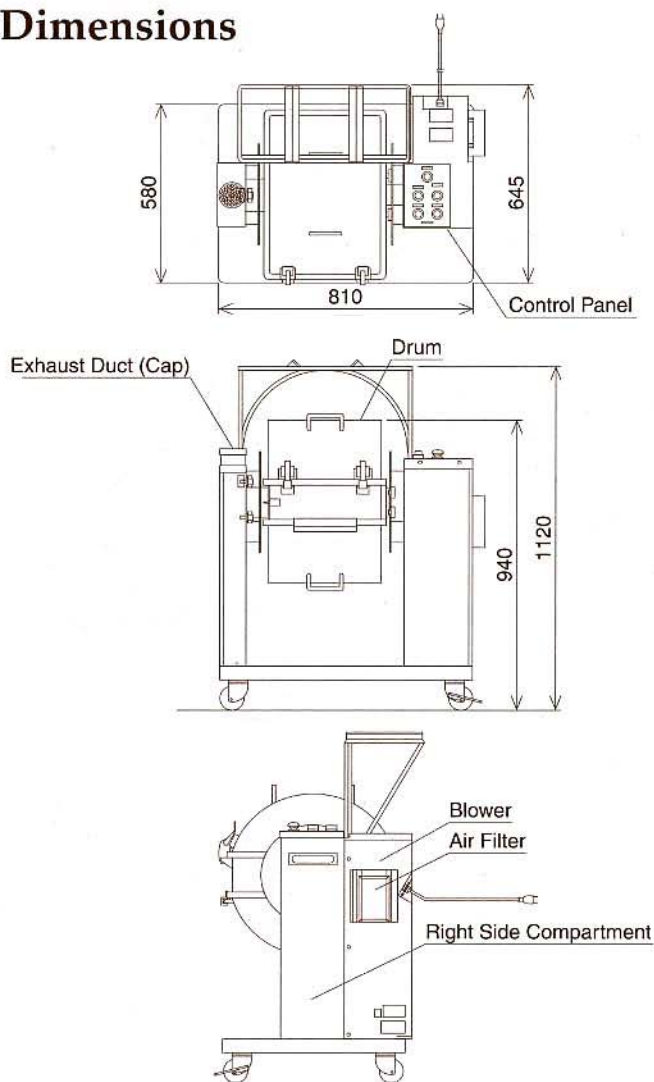

## Colonnade® Vinegar



For best results, we recommend Suzumo's high-grade Colonnade® sushi vinegar *awasezu*. Pectin colloid in Colonnade® *awasezu* lends an appetizing gloss to the sushi rice *shari*. It also aids flavor retention and helps maintain alpha condition\* over longer periods in the refrigerator case (5°C).

\* Alpha condition: rice in its ideal state, containing an optimum amount of moisture, and maintaining its firmness and freshness. [cf. Beta condition: (particularly at 5°C) a condition typically caused by refrigeration, in which rice rapidly loses its flavor.]

\* Designs and specifications subject to change without notice.

\* Please follow the directions in the operations manual when handling the robot.

\* While capacity expresses the machine's performance capabilities, it is predicated upon the robot being operated correctly.



Allgemeine Großküchen-Organisation

ALGO GmbH

Berck-sur-Mer-Str. 9  
53604 Bad Honnef

Tel.: 0 22 24 - 94 43-15

Fax: 0 22 24 - 94 43-20

info@algo-gmbh.de

www.algo-gmbh.de